

Polyurethane (PU)

Polyurethane rigid foam board is a high molecular polymer made of isocyanate and polyether as the main, In foaming agent, raw materials, catalysts, flame retardants and special, other additives, mixed through equipment and foamed on-site by high-pressure spraying.



Thickness: 10mm~400mm,

Length : 1850-2700, Width 600-1200, Density: 40-43kg/m³, Single shift production capacity: 80m³/day



Fiberglass

Glass fiber reinforced plastic (FRP) is also called

GFRP, which means fiber reinforced plastic. It generally refers to glass fiber reinforced unsaturated polyester, epoxy resin and phenolic resin matrix. Reinforced plastics with glass fiber or its products as reinforcing materials are called glass fiber reinforced plastics, or FRP.

Thickness: 1.2mm~3mm,
Length : 100m/rolls, Width :2800mm,Single shift
production capacity: 1300m/day
Customization is also available.

Lightweight, with good economic benefits

1. Fully enclosed polyurethane plate bonded to GFRP structure.
2. Refrigerated and Refrigerator car have no metal framework and connectors.
3. The box body is lighter than similar products and can effectively reduce transportation costs.

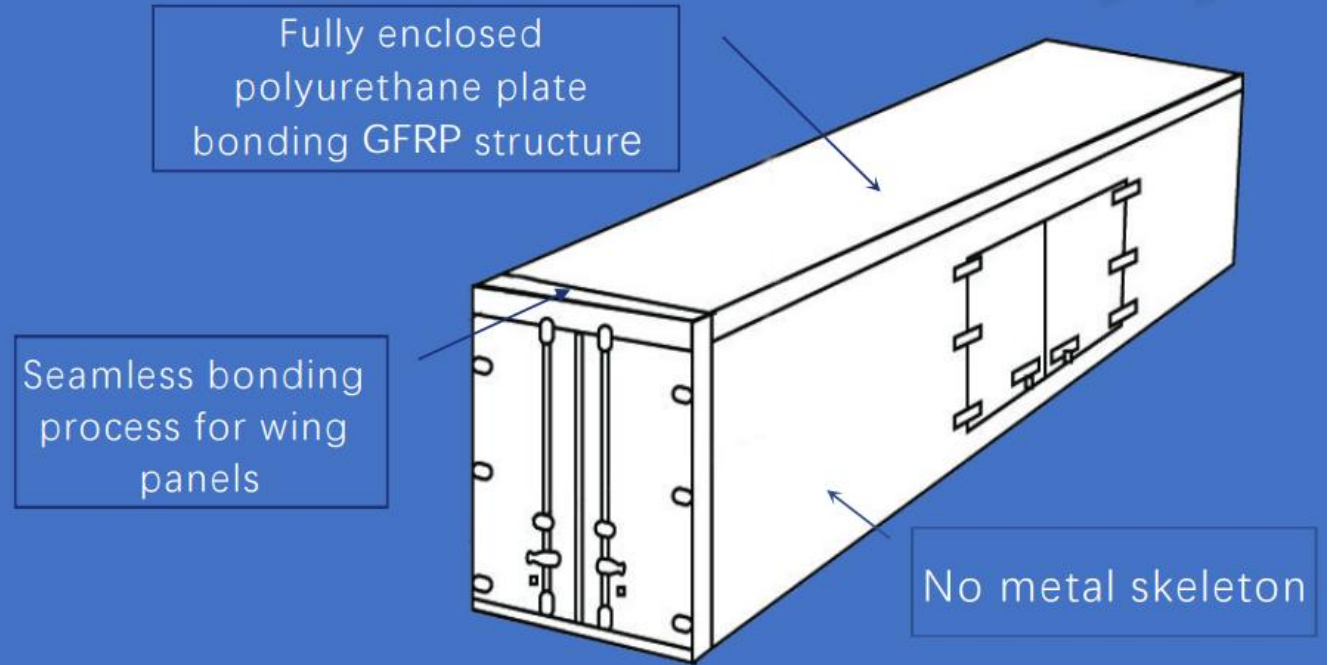

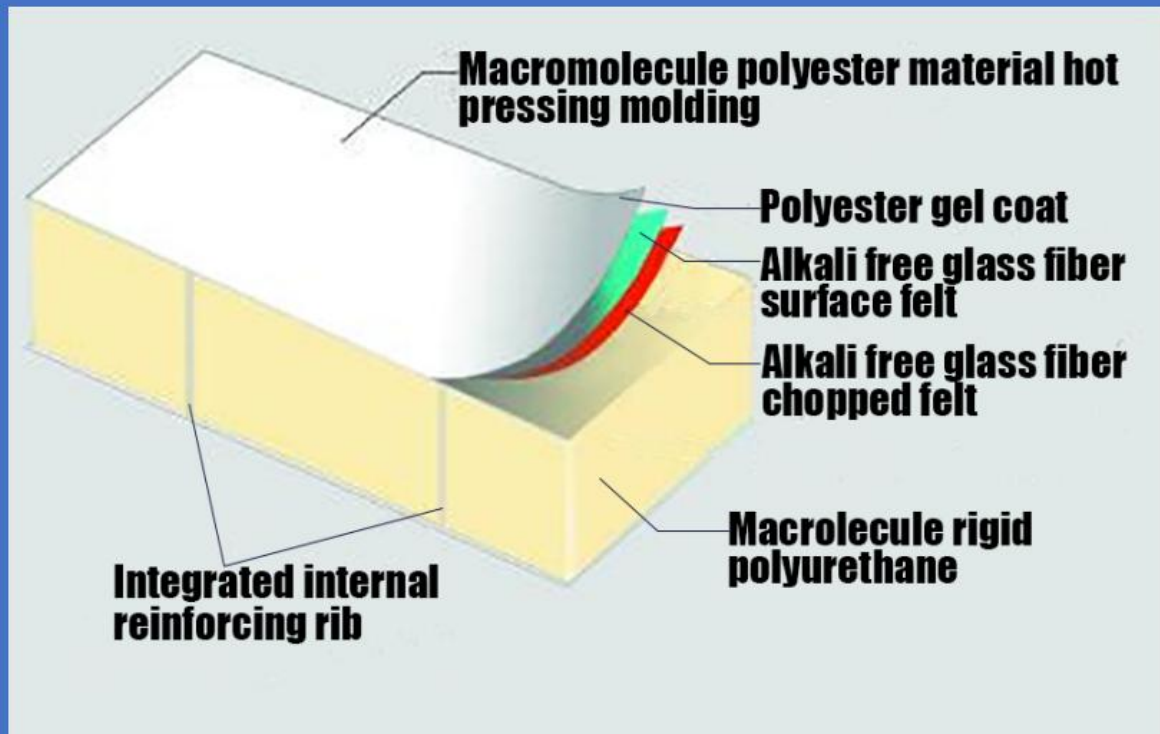

Durable and sturdy structure

1. The box body is made of high molecular polyester material through hot pressing, and adopts a fully enclosed structure.
2. The integrated internal reinforcing rib greatly increases the strength of the box body panel.
3. The bonding of the board adopts high-strength and high sealing adhesive to form a whole. Has good corrosion resistance.

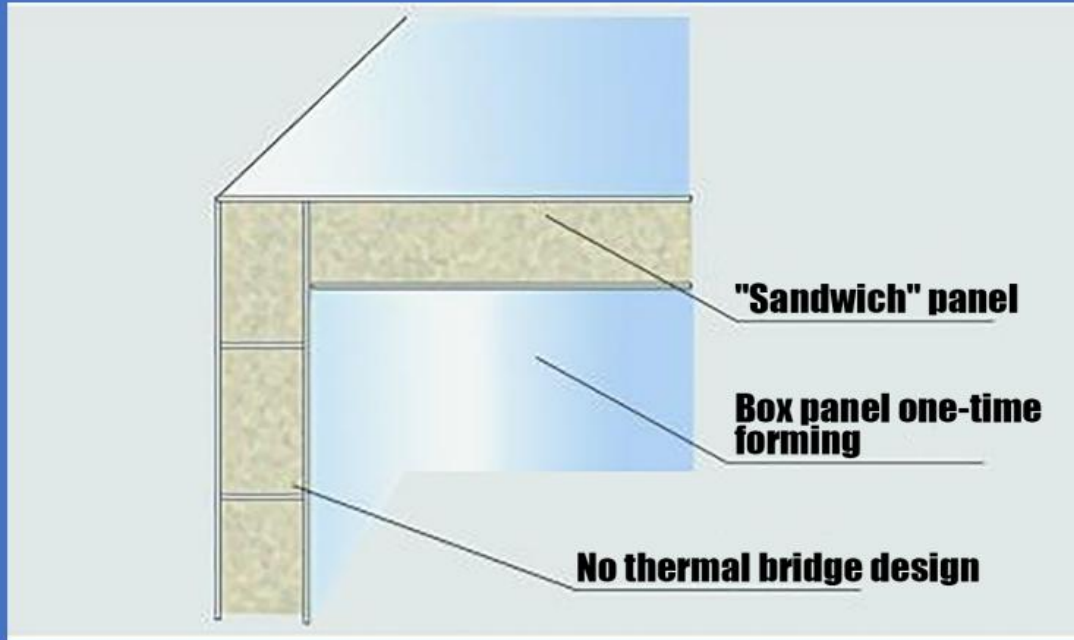

Durable and sturdy structure

4. Italian "sandwich" plate making technology, German imported press, vacuum hot pressing for the panel, one-time molding.

5. Without metal framework and connectors. The weight of the box body is 15-25% lighter than similar products. Effectively reduce transportation costs.

Choice what you need



Standard(clean)



Guide rail of bottom Aluminum steel of bottom



Ventilating slot(bottom)



304 Stainless skin



Ventilating slot(side)



Groove ventilating slot



Guide rail of meat hook



Goods shelf



Separate box



Mobile sparate hard board



Mobile sparate soft board



CKD SHIPMENT

CBU SHIPMENT

CKD SHIPMENT





- Equipment Capability:

- Length * Width 14500mm *
3000mm

- Mold thickness: 83/103 mm

- (different heights can also be
customized)

Sandwich hot pressing

process



- Equipment Capability: Length * Width 14600mm * 3000mm
- Mold thickness: 50/60/80/100 mm
- (different heights can also be customized)

Integrated molding injection foaming process



China VI Emission Standard Vehicle

9.6-meter FAW chassis refrigerator truck



Integrated semi trailer refrigerated truck



Product Features

1. The overall structure of the carriage is aluminum alloy, and the top panel has an automatic lifting sunroof. The top plate of each layer has ventilation ducts to ensure an internal temperature of 25-32 °C.
2. The button in the driver's cab is turned on. In summer, the refrigerator is turned on. The fan blows cold steam and filtered fresh air into the carriage to cool down, and automatically controls the air volume based on the temperature detected by the temperature control head. In winter, the refrigerator does not need to be turned on. The heater automatically turns on the air heater according to the temperature detected by the sensor, thereby sending hot air into the carriage.



Technical Parameter

9.6-meter FAW pneumatic type bulk feed transport vehicle



Technical Parameter

Model	QYK5310GFL6	Chassis	CA1310P2K2L7T4BE6A80
Wheelbase	1900+4500+1350(mm)	Vehicle size	12000×2500,2530×3900,4000(mm)
Engine	CA6DM2-42E65	Curb weight	15650kg
Volume	31.95 m ³		

Product Features

The pneumatic type bulk feed tanker is suitable for transporting granular feed and powder in large chicken farms, pig farms, fish farms, and other farms.

The pneumatic type is not limited by distance, and the granular materials in the tank are loaded and unloaded clean, with no residue to reduce waste.

YAKA114

13.6-meter bulk feed delivery Semi Trailer



Product Details

Technical Parameter

Model:	QYK9400ZSL	Tire Size	12R22.5 12PR,11.00R20 12PR
Wheelbase	7290+1310+1310(mm)	Vehicle size	13590×2550×3900,4000(mm)
Volume	60m ³	Curb weight	11320(Kg)





vehicle configuration

Refrigeration system+heating system+humidification system+environmental control system+monitoring system+transportation system.

This kind of car body is a plate assembly structure. The car body is designed without cold bridge. The inner and outer skins are made of a whole high-quality food grade glass steel plate. The interlayer is made of environment-friendly Cyclopentane polyurethane foam insulation material. Stiffeners are set between the plates.

Density: 39-42Kg/m³

Thermal conductivity: 0.24W/m²-K

refrigeration system

We use Japanese Yangma generators, German Bok compressors, American Gates components, and all electronic control systems using international excellent brands. The display and PLC use German brands such as Siemens.

YAKA I 01

9.6-meter Dongfeng Ventilated poultry transport vehicle(Chicks、 Ducklings)



The diversified configuration of this vehicle, in addition to the ordinary van vehicle's rainproof, anti-theft, and dustproof features.

In addition to other functions, it also has good ventilation and thermal insulation functions, which can meet the transportation needs of Poultry farming enterprises in all regions, all days and all seasons, solve the customer's worries, and can also carry out special design and install various special devices according to the customer's regional location and the type of transportation; Install remote control systems, sprinkler, etc. to meet customer usage requirements. This greatly reduces the loss rate of poultry caused by transportation, and plays a guarantee role in improving the economic benefits of breeding and breeding enterprises.

Product Details

